

use & care guide

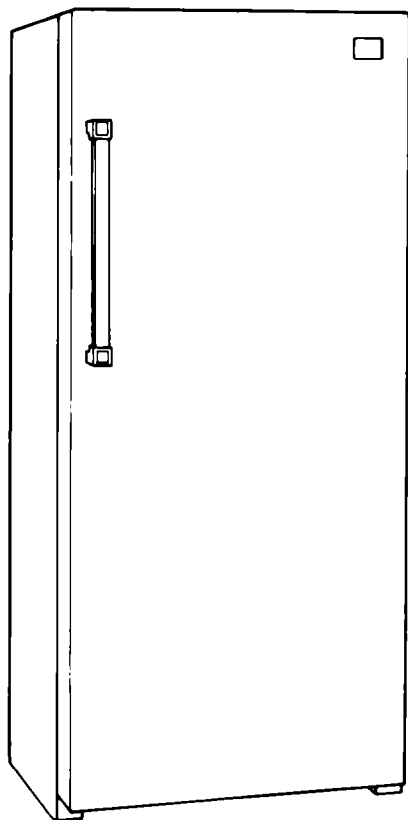

MANUAL DEFROST REFRIGERATOR- FREEZER

**Model EL11PC
and
Model EL13PC**

Freezers, Refrigerator-Freezers, Ice Makers, Dishwashers, Built-In Ovens, and Surface Units, Ranges, Microwave Ovens, Trash Compactors, Room Air Conditioners, Dehumidifiers



Please read this Use and Care Guide before you do anything else...

This booklet tells you how to start your refrigerator, clean it, move shelves and adjust controls. It even tells you what new sounds to expect from your refrigerator.

Treat your new refrigerator with care. Use it only to do what home refrigerators are designed to do.

Parts and features

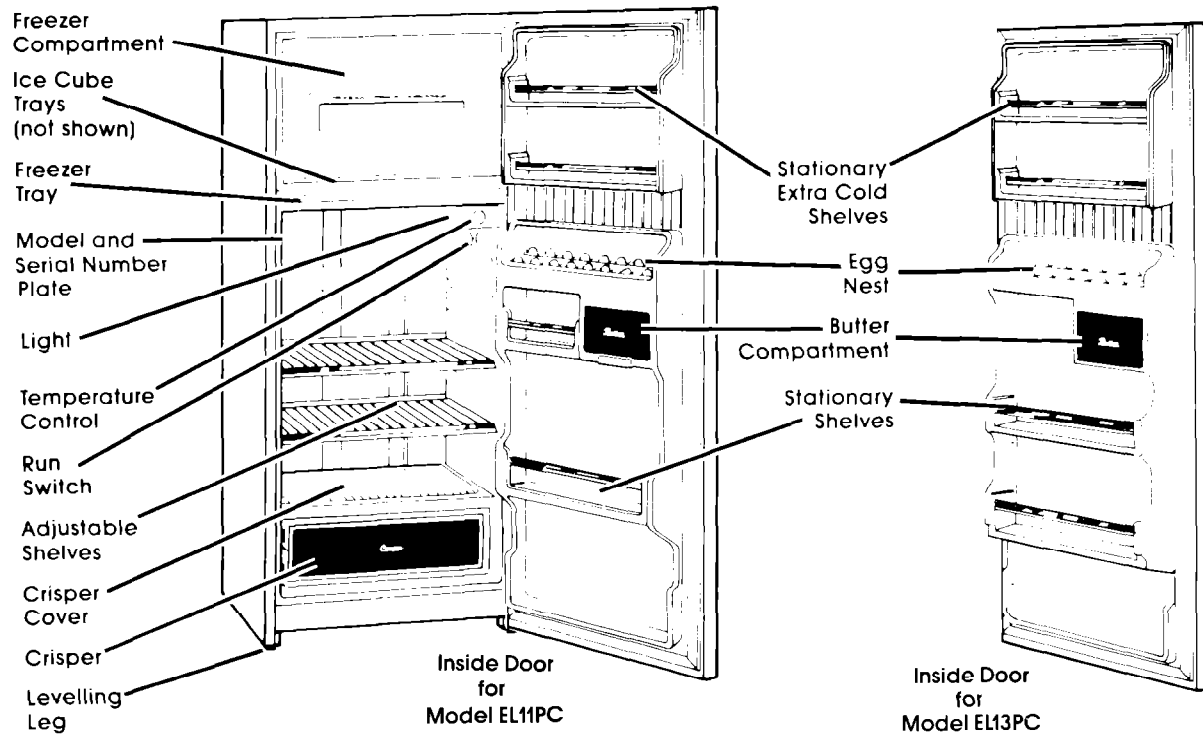

Copy your Model and Serial Numbers here...

When you need service, or call with a question, have this information ready:

1. **Complete** Model and Serial Numbers from the plate located as shown).
2. Purchase date from sales slip.

Copy this information in these spaces. Keep this book, your warranty and sales slip together in a handy place.

Please complete and mail the Owner Registration Card furnished with this product.

Model Number

Serial Number

Purchase Date

Service Company and Telephone Number

Contents

	Page		Page
SAFETY FIRST	3	Sounds You May Hear	6
BEFORE YOU PLUG IT IN	3	Energy Saving Tips	7
Install Properly	4	DEFROSTING AND CLEANING YOUR	
Level Refrigerator	4	REFRIGERATOR	7
Remove Sales Labels	4	Defrosting the Freezer Compartment ...	7
Clean It	4	Cleaning the Refrigerator	8
Plug It In	4	Cleaning Chart	8
Turn It On	4	FOOD STORAGE GUIDE	9
USING YOUR REFRIGERATOR	5	VACATION AND MOVING CARE	10
Setting the Control	5	IF YOU NEED SERVICE OR ASSISTANCE ..	11
The Freezer Tray	5	1. Before Calling for Assistance	11
Changing the Light Bulb	6	2. If You Need Assistance	11
Adjusting the Refrigerator Shelves	6	3. If You Need Service	11
Removing Crisper and Crisper Cover ...	6	4. If You Have a Problem	11
Ice Cube Tray	6		

©1986 Whirlpool Corporation

Safety first

Child entrapment, and suffocation, are not things of the past. Junked or abandoned refrigerators are still dangerous...even if they will "just sit in the garage for a few days."

If you are getting rid of your old refrigerator, do it safely. Please read the enclosed safety booklet from the Association of Home Appliance Manufacturers. Help prevent accidents.

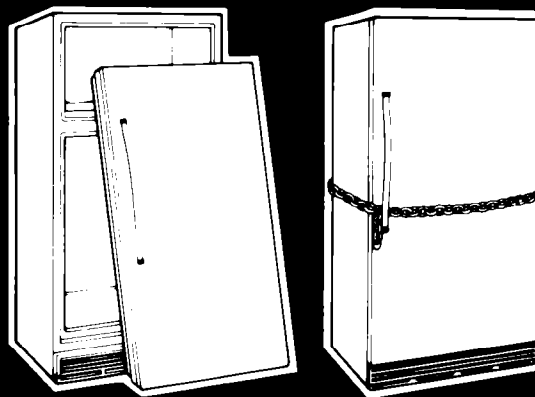

Before you plug it in

IMPORTANT

Before using your refrigerator, you are personally responsible for making sure that it...

- is installed and leveled on a floor that will hold the weight, and in an area suitable for its size and use.
- is connected only to the right kind of outlet, with the right electrical supply and grounding. (Refer to your "Electrical Requirements and Grounding Instructions.")
- is used only for jobs expected of home refrigerators.

- is not near an oven, radiator or other heat source.
- is properly maintained.
- is out of the weather.
- is used in an area where the room temperature will not fall below 55° F (13° C).
- is not used by those who may not understand how it should be used.
- is not loaded with food before it has time to get properly cold.

Install properly...

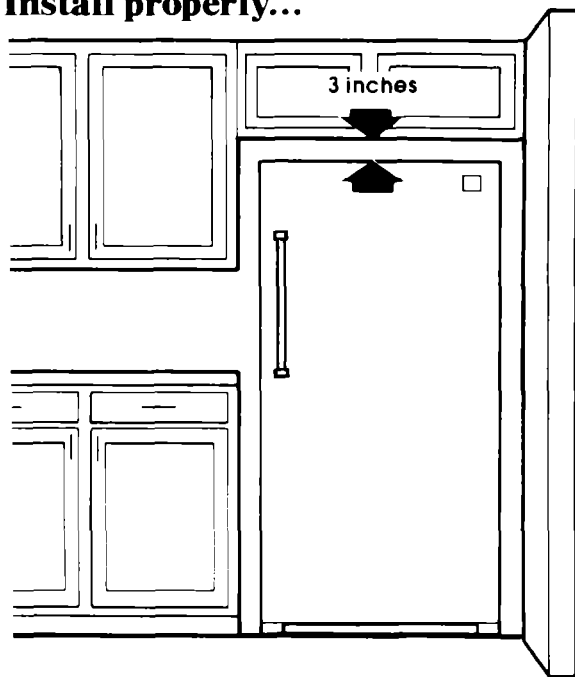

1. Allow 3 inches (7.5 cm) between overhead cabinets and the refrigerator top.
2. Allow at least an inch (2.5 cm) between the refrigerator condenser and the wall.
3. Allow 1/2 inch (1.25 cm) on each side of the refrigerator for ease of installation.
4. If the refrigerator is to be against a wall, you might want to leave enough space so the door can be opened wider.

Level refrigerator...

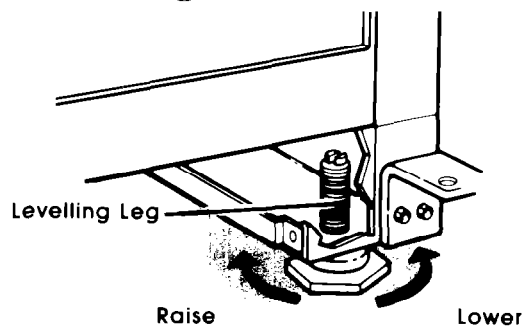

1. Keep the 4 bolts that held refrigerator in shipping crate. They are the levelling legs.
2. Screw these bolts all the way into bolt holes at the bottom corners of refrigerator.
3. Adjust each leg until the refrigerator won't rock. Slide refrigerator into place.
4. Adjust front legs to level the refrigerator.
 - To raise corners, turn legs in direction shown.
 - To lower corners, turn legs in direction shown.
5. Check with level.

Remove sales labels...

Remove the Consumer Buy Guide label, tape and any **inside** labels before using the refrigerator.

To remove any remaining glue:

1. Rub briskly with thumb to make a ball then remove.
- OR**

2. Soak area with dishwashing detergent solution (1 teaspoon detergent in 1 quart warm water) before removing glue as described in step 1.

DO NOT USE rubbing alcohol or flammable or toxic solvents, such as acetone, gasoline, carbon tetrachloride, etc. These can damage the material.

NOTE: DO NOT REMOVE ANY PERMANENT INSTRUCTION LABELS INSIDE YOUR REFRIGERATOR.

Do not remove the Tech Sheet fastened under the refrigerator at the front.

Clean it...

Clean your refrigerator before plugging it in or using it. See cleaning instructions on page 7.

Plug it in...

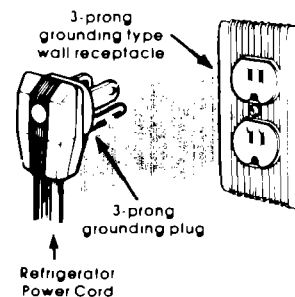

RECOMMENDED GROUNDING METHOD

A 115 Volt, 60 Hz., AC only 15 or 20 ampere fused and properly grounded electrical supply is required. It is recommended that a separate circuit serving only this appliance be provided.

Do not use an extension cord. Use a receptacle which cannot be turned off with a switch or pull chain. See individual electrical requirements and grounding instruction sheet in your literature package.

Turn it on...

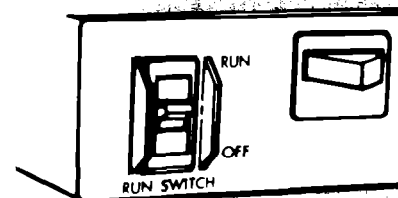

- Move run switch to RUN

NOTE: The refrigerator motor will not operate until the run switch is on RUN.

Using your refrigerator

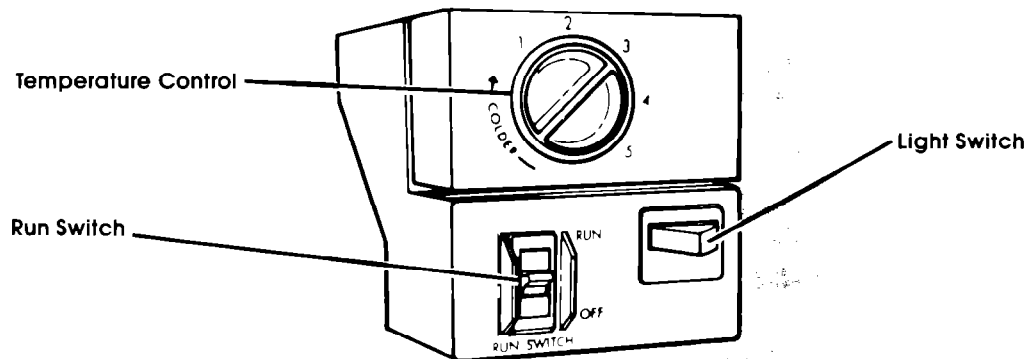

Setting the control ...

The control for the refrigerator temperature is in the refrigerator. When the refrigerator is plugged in and the run switch is moved to RUN

Give the refrigerator time to cool down completely before adding food. (This may take several hours.)

This setting should be about right for normal household refrigerator usage.

The control will be set about right when milk or juice is as cold as you like. In hot weather or if the door is opened often, turn the control to a higher number to keep the temperature you like. If the milk or juice is too cold or refrigerator items start to freeze, turn the control to a lower number or adjust the freezer tray damper. Wait 24 hours after an adjustment is made before further change is made to the controls.

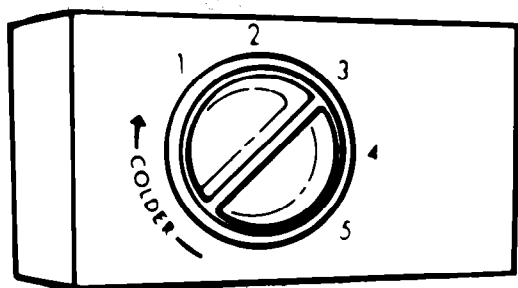

- Set the THERMOSTAT CONTROL to 3

The freezer tray...

The freezer tray is located under the freezer compartment.

The damper at the rear of the freezer tray helps control the refrigerator temperature for warm weather operation. The damper can be adjusted for proper cooling and defrosting of the refrigerator.

To adjust the damper:

1. Pull out the freezer tray.
2. Lift out the damper from the rear of the tray.
3. Slide damper into the desired position.

NOTE: "B, C, D" positions provide fine cooling adjustments to best meet your cooling needs in warm weather.

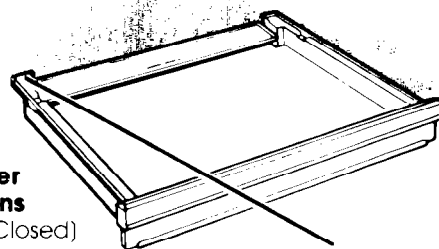

Damper Positions

- A - (Closed)
- B -
- C -
- D -
- E - (FULL Open)

"A" position for normal cooling and defrosting.

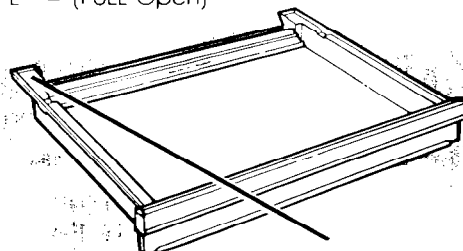

"E" position for warm weather setting.

Changing the light bulb...

WARNING: Before removing the light bulb, either unplug the refrigerator or disconnect the electricity leading to the refrigerator at the main power supply. Shock and injury can occur if electricity remains connected.

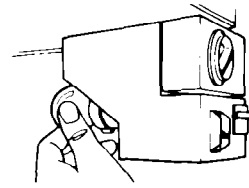

1. Reach behind control console to find bulb.
2. Remove bulb.
3. Replace with a 40-watt (maximum) appliance bulb.

Adjusting the refrigerator shelves...

1. First, remove food from shelf.
2. Slide shelf straight out to stop.
3. Lift front.
4. Slide the rest of the way out.

Replacing Shelf:

1. Fit back of shelf on top of guides with wire stops on the bottom of guides.
2. Lift front, slide shelf in until it clears guide stops.

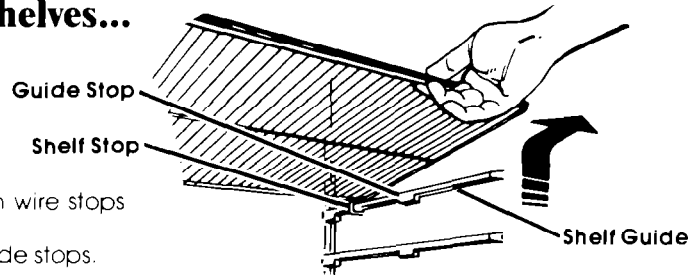

Removing crisper and crisper cover...

Lift the Front. Then the Back.

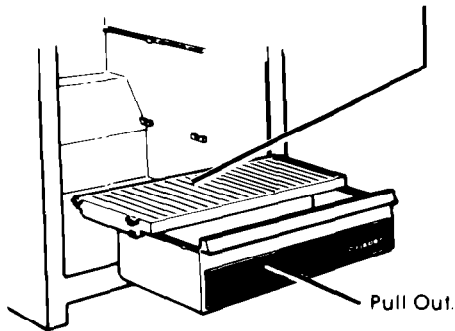

Removing Crisper:

- Slide crisper straight out.

Remove Cover:

1. Lift back, then slide to the rear until the front can be lifted.
2. Lift cover up and out.

Replacing Cover:

1. Slide the front cover tabs into the back of the front supports on the refrigerator wall.
2. Lower back into place.

Ice cube trays...

To remove ice:

1. Hold tray at both ends.
2. Slightly twist.

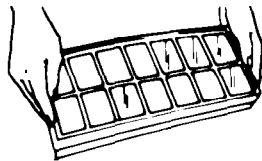

For best results when freezing ice cubes, place ice cube trays side-by-side in bottom of freezer compartment.

If cubes are not used, they may shrink. The longer cubes are stored, the smaller they get.

Sounds you may hear...

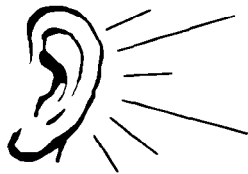

Your new refrigerator may make sounds that your old one didn't. Because the sounds are new to you, you might be concerned about them. Don't be. Most of the new sounds are normal. Hard surfaces like the floor, walls and cabinets can make the sounds seem louder.

The following chart describes the kinds of sounds that might be new to you, and what may be making them.

Possible Sounds:

- **Water Sounds:**
- **Running Sounds:**

Probable Causes:

When the refrigerator stops running, you may hear gurgling in the tubing for a few minutes after it stops.

Your refrigerator has a high-efficiency compressor and motor. It will run longer than older designs. It may even seem to run most of the time.

Energy saving tips...

You can help your refrigerator use less electricity.

- Check door gaskets for a tight seal. Level the cabinet to be sure of a good seal.
- Clean the condenser coil regularly.
- Open the door as few times as possible. Think about what you need before you open the door. Get everything out at one time. Keep foods organized so you won't have to search for what you want. Close door as soon as food is removed.
- Go ahead and fill up the refrigerator, but don't overcrowd it so air movement is blocked.

- It is a waste of electricity to set the refrigerator and freezer temperatures colder than they need to be. If ice cream is firm in the freezer and drinks are as cold as your family likes them, that's cold enough.
- Make sure your refrigerator is not next to a heat source such as a range, water heater, furnace, radiator, or in direct sunlight.

Defrosting and cleaning your refrigerator

The freezer compartment in your refrigerator should be defrosted whenever frost builds up to ¼-inch (6 mm).

The entire refrigerator should be cleaned about once a month to help prevent odors from building up. Of course, spills should be wiped up right away.



Defrosting the freezer compartment ...

1. Move the Run Switch to "OFF".
2. Remove food and ice cube trays. Wrap food in newspaper and put in a cooler to keep frozen.
3. Make sure the freezer tray damper is in the "A" position.
4. Place a pan of hot water in the freezer compartment to speed defrosting. Leave door open.
5. **CAUTION: Do not use any type of electric defroster or sharp utensils (ice pick, knife, etc.)** to speed defrosting. These can cause damage. Scrape with plastic window scraper.
6. Replace hot water every 10 to 15 minutes.
7. Soak up defrost water with a cloth or sponge.
8. Empty defrost water from freezer tray. (Pull out to stop; lift front slightly; pull out the rest of the way.)
9. Clean compartment and freezer tray with a solution of two tablespoons (26 g) of baking soda and one quart (.95 l) of warm water. Rinse well and dry.
10. Replace food and ice cube trays.
11. Move the Run Switch to RUN.

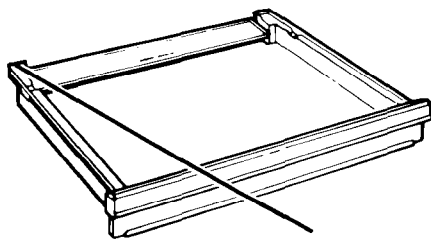

"A" position for normal cooling and defrosting.

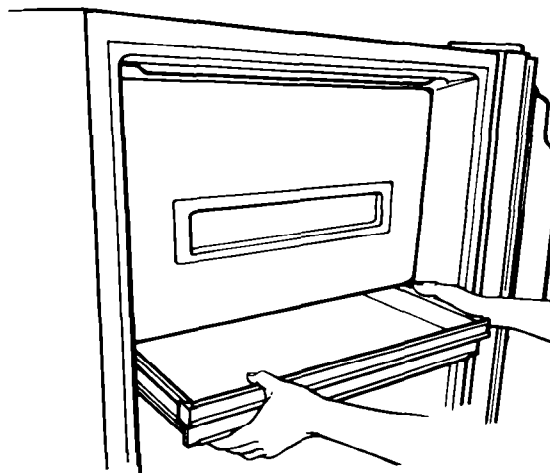

Cleaning the refrigerator...

To clean your refrigerator, move the Run Switch to OFF, **unplug it**, take out all removable parts, and clean it according to the following directions.

When cleaning is complete, replace all refrigerator parts, plug it in, and move the Run Switch to RUN.

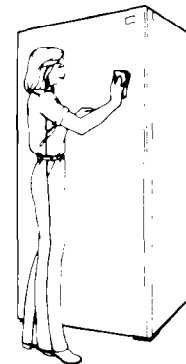

Cleaning chart...

Part	What to use	How to clean
Removable parts (shelves, crisper, etc.)	Sponge or cloth, mild detergent and warm water.	<ul style="list-style-type: none"> • Wash removable parts with warm water and a mild detergent • Rinse and dry
Outside	Sponge, cloth or paper towel; mild detergent; appliance wax (or good auto paste wax)	<ul style="list-style-type: none"> • Wash with warm water and a mild detergent. Do not use abrasive or harsh cleansers. • Rinse and dry • Wax painted metal surfaces at least twice a year with appliance wax or a good auto paste wax. Apply wax with a clean, soft cloth. Do not use wax on plastic parts.

Waxing painted metal surfaces provides rust protection.

Inside walls (freezer compartment should be allowed to warm up so cloth won't stick.)	Sponge, soft cloth or paper towel, baking soda, warm water, mild detergent	<ul style="list-style-type: none"> • Wash with warm water and <ul style="list-style-type: none"> – mild detergent or – baking soda (2 tablespoons [26 g] to 1 quart [95 l] warm water) • Rinse and dry
Door liners and gaskets	Sponge, soft cloth or paper towel, mild detergent, warm water	<ul style="list-style-type: none"> • Wash with mild detergent and warm water • Rinse and dry

DO NOT USE Cleaning waxes, concentrated detergents, bleaches or cleansers containing petroleum on plastic parts.

Dark Plastics (covers and panels)	Mild detergent and warm water, soft, clean sponge and soft, clean cloth	<ul style="list-style-type: none"> • Wash with a soft grit-free cloth or sponge • Rinse and dry with a damp grit-free cloth or chamois
-----------------------------------	---	--

DO NOT USE paper towels, window sprays, scouring cleansers, or flammable or toxic solvents like acetone, gasoline, carbon tetrachloride, etc. These can scratch or damage the material.

Condenser coils	Use vacuum cleaner with brush attachment	<ul style="list-style-type: none"> • Clean dust and lint from condenser coils behind the refrigerator at least every other month. Be careful, the fins on the coils are sharp.
Floor under refrigerator	Usual floor cleaners.	<ul style="list-style-type: none"> • Slide refrigerator out away from wall • Wash floor. • Slide refrigerator back into place. • Check to see if the refrigerator is level.

Food storage guide

Leafy vegetables... (lettuce, celery and parsley). Before storing, remove the store wrap and trim off bruised areas. Wash in cool water and drain slightly. Water should be clinging to the greens as they go into the crisper. This water provides the atmosphere of high humidity necessary for keeping the leafy vegetables fresh and crisp during storage.

Vegetables with skins... (tomatoes and peppers) Wash, dry and store in a crisper

Fruits... Wash, dry and store in a crisper with vegetables such as tomatoes. Berries keep better if not washed or hulled until ready to use. Sort, then store berries in a loosely closed paper bag and store on refrigerator shelf

Meat*... Meat is perishable and proper care is essential to maintaining its keeping qualities. Store fresh meat on the interior refrigerator shelves. Refer to the chart on this page for recommended refrigerator food storage times.

Fresh meat, prepackaged by the meat retailer... Store in refrigerator in the original wrapping. Refer to the chart, following, for recommended refrigerator storage times

Fresh meat, not prepackaged... Remove from the market wrapping paper, wrap in aluminum foil. Refer to chart on this page for recommended storage times.

Prepackaged frozen meat... Place in the freezer compartment or freezer tray immediately after purchase unless it is to be defrosted for cooking.

Cooked meats (leftovers)... Cool within one to two hours after cooking, then cover or wrap tightly with plastic wrap or aluminum foil to prevent drying, and store in the refrigerator. Bones may be removed to conserve storage space, but meat should be left in as large a piece as possible

Meats cooked in liquid for future serving should be cooled uncovered, within one to two hours, then covered and stored in the refrigerator. To speed cooling, when meat is cooled in liquid, the pan containing the cooked meat may be set where there is good circulation of cool air, or it may be cooled by setting the pan in cold or running water.

Cured and smoked meats... Keep best in original wrapping. After opening, rewrap tightly in plastic wrap or aluminum foil

Cooked meat... Wrap or cover tightly with plastic wrap or aluminum foil.

* Courtesy of Nat'l Live Stock and Meat Board

Cold cuts... Store them in their original wrapping until you are ready to use. Once the package is opened, tightly rewrap unused cold cuts in plastic wrap or aluminum foil.

STORAGE CHART FOR FRESH AND CURED MEAT*

Type	Approximate Time (days)
Variety Meats	1 to 2
Chicken	1 to 2
Ground Beef	1 to 2
Steaks and Roasts	3 to 5
Cured Meats	7 to 10
Bacon	5 to 7
Cold Cuts	3 to 5

*If meat is stored a day or two longer than the above recommended time, wrap in air tight packaging and store in freezer compartment.

NOTE: Fresh fish and shellfish should be used the same day purchased

Eggs... Store without washing in the original carton or use the egg nest in the door

Milk... Wipe milk cartons. For best storage, place milk on top interior shelf.

Beverages... Wipe bottles and cans. Store on lower door shelves beneath the egg nest or interior shelves.

Butter... Store daily needs on serving dish in butter compartment. When storing an extra supply, wrap in air-tight packaging and store in freezer compartment or on top door shelves.

Cheese... Store in original wrapping until you are ready to use. Once the package is opened, rewrap tightly in plastic wrap or aluminum foil. Store on interior refrigerator shelves.

Condiments... Store catsup, mustard, jelly, olives, pickles, etc. on door shelves. **NOTE:** Store bottled and canned items on door shelves beneath the egg nest.

Leftovers... Always cover the container with plastic wrap or aluminum foil to keep food from drying. Store on refrigerator shelves.

Ice cream... Store on the bottom of the freezer compartment. Once package is opened, place a piece of aluminum foil snugly against the surface of the ice cream. This will prevent ice crystals from forming.

Frozen soups, juices... Store in freezer compartment.

Packaged frozen food... Store in freezer compartment or in the full-width freezer tray.

Frozen meats... Wrap in freezer packaging material and store in freezer compartment or freezer tray.

Ice trays... Place on the bottom of the freezer compartment.

Vacation and moving care



Short vacations...

No need to shut off the refrigerator if you will be away for less than four weeks. Use up perishables.

Long vacations...

Remove all food if you are going for a month or more.

Turn the Temperature Control to OFF, unplug the refrigerator and clean it...rinse well and dry. Tape rubber or wood blocks to the door...keeping it open far enough for air to get in. This will keep odor and mold from building up.

WARNING: Tape blocks out of a child's reach...do not allow children near the refrigerator when the door is blocked open. They may become injured or trapped.

To restart refrigerator, see instructions on page 4.

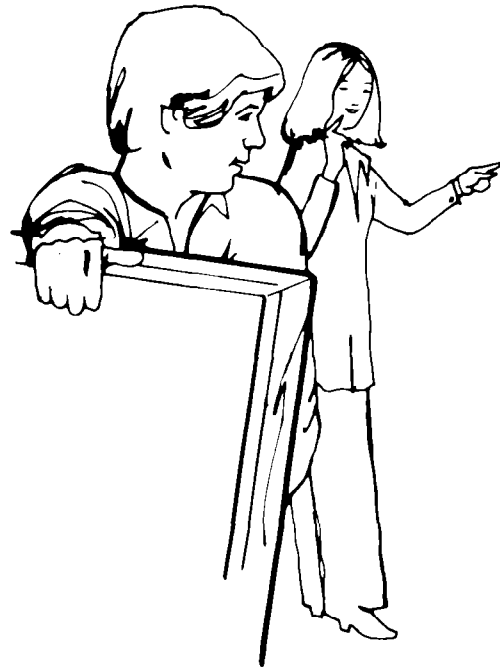

Moving...

Remove all food. Pack frozen foods in dry ice. Unplug the refrigerator and clean it thoroughly.

Remove everything that comes out. Wrap all parts well and tape them together so they don't shift and rattle.

Screw in the levelling legs; tape the door shut; tape the electric cord to the cabinet. When you get to your new home, put everything back and refer to page 4.

QUESTIONS?

...call your
COOL-LINE®
service
assistance
telephone
number (page 11).



If you need service or assistance, we suggest you follow these four steps:

1. Before calling for assistance...

Performance problems often result from little things you can find and fix yourself without tools of any kind.

If your refrigerator will not operate:

- Is the power supply cord plugged into a live circuit with the proper voltage? (See page 4.)
- Have you checked your home's main fuses or circuit breaker box?
- Is the Run Switch on RUN?

If there is a rattling or jingling noise, or other unfamiliar sounds:

- Is something on top or behind the refrigerator making noise when the refrigerator is running?

If the light does not work:

- Have you checked your home's main fuses or circuit breaker box?
- Is the power supply cord plugged into a live circuit with the proper voltage? (See page 4.)

If a bulb is burned out:

- See instructions for changing light bulbs on page 6. Use appliance bulbs only.

If the motor seems to run too much:

- Is the condenser, behind the refrigerator, free from dust and lint?
- On hot days, or if the room is warm, the motor naturally runs longer.
- If the door has been opened a lot, or if a large amount of food has been put in, the motor will run longer to cool down the interior.
- Is frost build-up more than 1/4 inch (6 mm)?

Remember: Motor running time depends on different things: number of door openings, amount of food stored, temperature of the room, setting of the control and damper position.

2. If you need assistance* ...

Call Whirlpool COOL-LINE® service assistance telephone number. Dial free from:

Continental U.S. (800) 253-1301
 Michigan (800) 632-2243
 Alaska & Hawaii (800) 253-1121

and talk with one of our trained Consultants. The Consultant can instruct you in how to obtain satisfactory operation from your appliance or, if service is necessary, recommend a qualified service company in your area.



FSP is a registered trademark of Whirlpool Corporation for quality parts. Look for this symbol of quality whenever you need a replacement part for your Whirlpool appliance. FSP replacement parts will fit right and work right because they are made to the same exacting specifications used to build every new Whirlpool appliance.

3. If you need service* ...



Whirlpool has a nationwide network of franchised TECH-CARE® Service Companies. TECH-CARE service technicians are trained to fulfill the product warranty and provide after-warranty service, anywhere in the United States. To locate

TECH-CARE service in your area, call our COOL-LINE service assistance telephone number (see Step 2) or look in your telephone directory Yellow Pages under:

APPLIANCES - HOUSEHOLD - MAJOR - SERVICE & REPAIR WHIRLPOOL APPLIANCES FRANCHISED TECH-CARE SERVICE SERVICE COMPANIES XYZ SERVICE CO 123 Maple 999-9999	OR	ELECTRICAL APPLIANCES - MAJOR - REPAIRING & PARTS WHIRLPOOL APPLIANCES FRANCHISED TECH-CARE SERVICE SERVICE COMPANIES XYZ SERVICE CO 123 Maple 999-9999
OR		
WASHING MACHINES, DRYERS & IRONERS - SERVICING WHIRLPOOL APPLIANCES FRANCHISED TECH-CARE SERVICE SERVICE COMPANIES XYZ SERVICE CO 123 Maple 999-9999		

4. If you have a problem* ...

Call our COOL-LINE service assistance telephone number (see Step 2) and talk with one of our Consultants, or if you prefer, write to:

Mr. Robert Stanley
 Division Vice President
 Whirlpool Corporation
 2000 US-33, North
 Benton Harbor, MI 49022

*If you must call or write, please provide: model number, serial number, date of purchase, and a complete description of the problem. This information is needed in order to better respond to your request for assistance.



Making your world a little easier.

Part No. 1106976 Rev. A
©1986 Whirlpool Corporation

Printed in U.S.A.

Makers. Dishwashers, Built-In Ovens, and Surface Units, Ranges, Microwave Ovens, Trash Compactors, Room Air Conditioners, Dehumidifiers, Automatic Washers, Clothes Dryers

